



www.kmk-maszyny.com

VEGETABLE TECHNOLOGY



COMPREHENSIVE

TECHNOLOGICAL LINES

WE DESIGN AND PRODUCE COMPREHENSIVE TECHNOLOGICAL LINES FOR POTATOES, ONIONS AND ROOT VEGETABLES.

THE LINES PROVIDED BY US INCLUDE PROCESSES OF RECEIVING, CLEANING, GRADING, INSPECTION, WEIGHING AND PACKAGING.

EACH TECHNOLOGICAL LINE IS BASED ON AN INDIVIDUAL INQUIRY.

WHEN CREATING A CONCEPT OF A LINE, OUR DESIGNERS TAKE INTO ACCOUNT SPECIFIC NEEDS AND CAPABILITIES OF OUR CUSTOMERS.



COMPREHENSIVE ONION LINE FOR AUTOMATIC PACKING WITH MODULAR BUNKERS

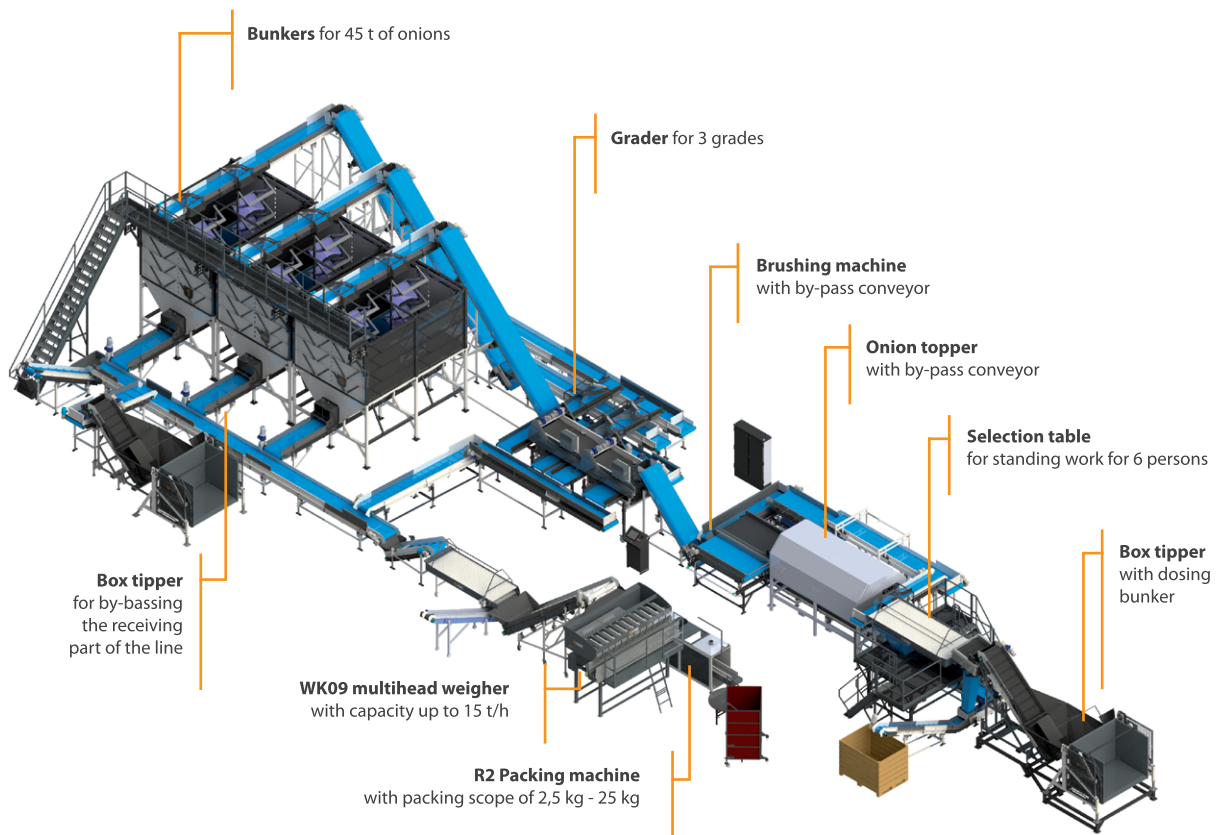



POTATO LINE
FOR AUTOMATIC PACKING
WITH MODULAR BUNKERS

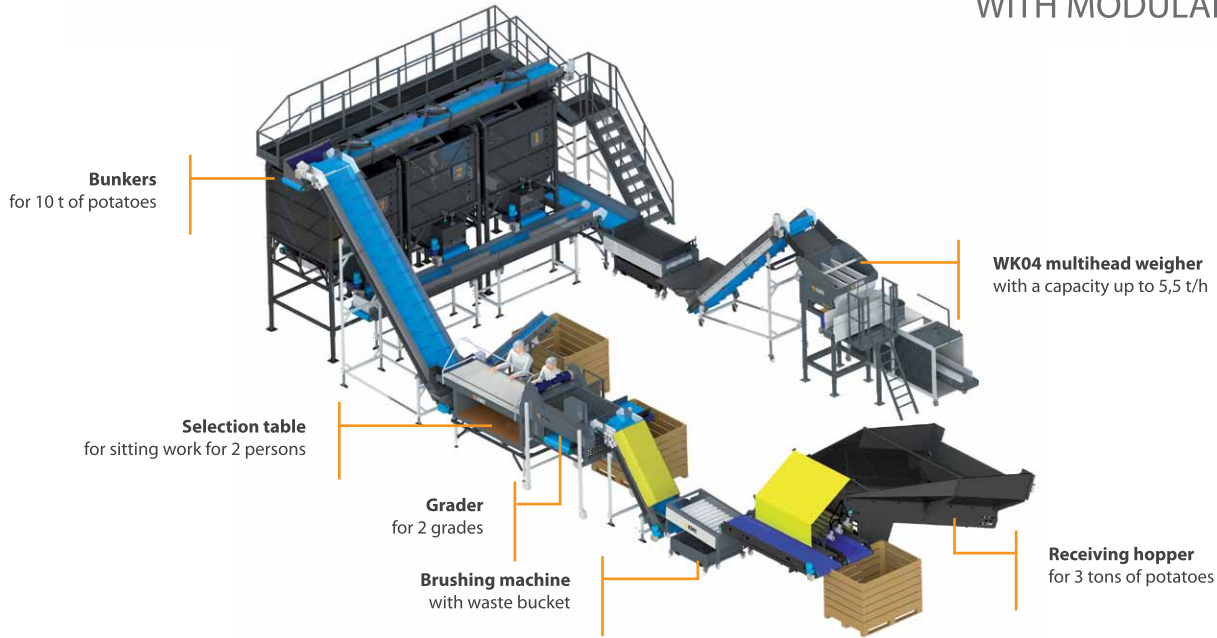

POTATO LINE
FOR MANUAL PACKING

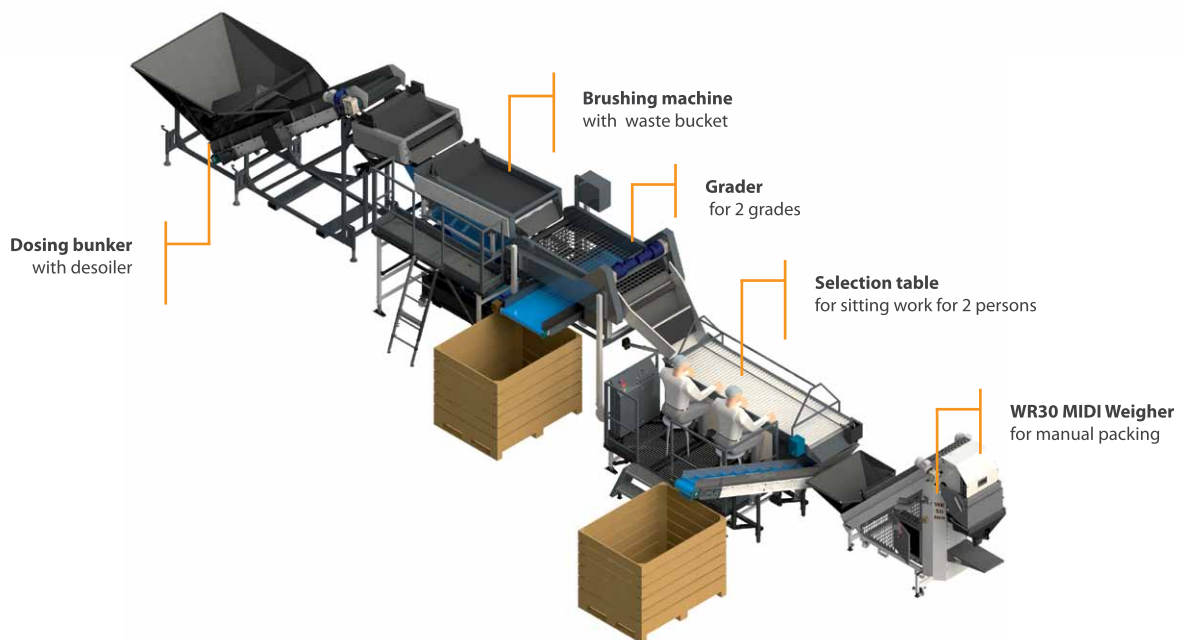

FULL

CONFIGURATION

FULL

CONTROL

KMK LINES ARE DESIGNED TO LET THE PRODUCT GO THROUGH ANY POSSIBLE PATH.

THIS FUNCTIONALITY IS GUARANTEED BY

MECHANICAL,

ELECTRIC

AND SOFTWARE ASSUMPTIONS OF A LINE.

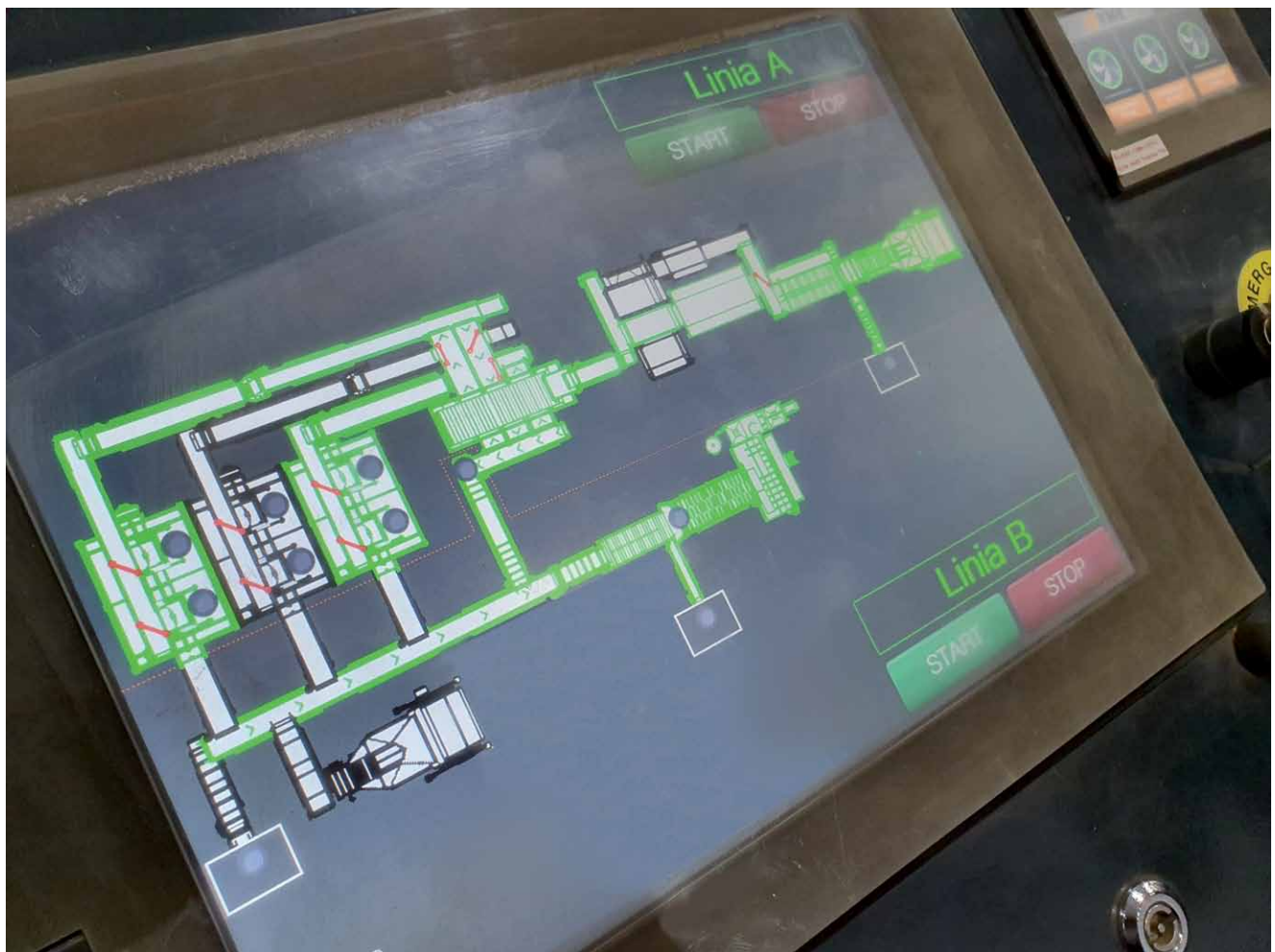

**BY-PASS
CONVEYORS**

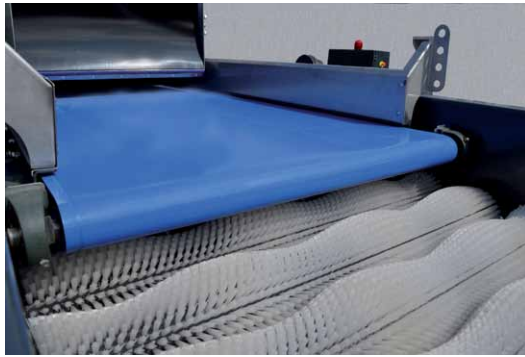

By-pass conveyor with a stepless adjustment
(moving over a machine)



By-pass conveyor
(moving left & right on a common frame with a machine)

SENSORS

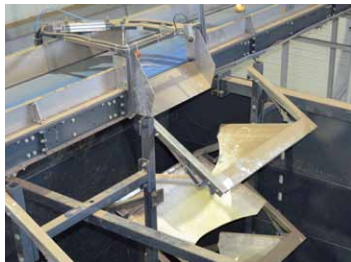

Product level sensor in a bunker



**Product level sensor in an intake
hopper of an elevator**



**Product level sensor in a dosing
bunker**

**ELECTRICALLY
CONTROLLED
PARTITIONS**



The partitions' position can be changed **manually at the central control box** or **automatically once a product level sensor** (e.g. in bunkers) is activated.

**CENTRAL
CONTROL BOX**



Central control box with switches

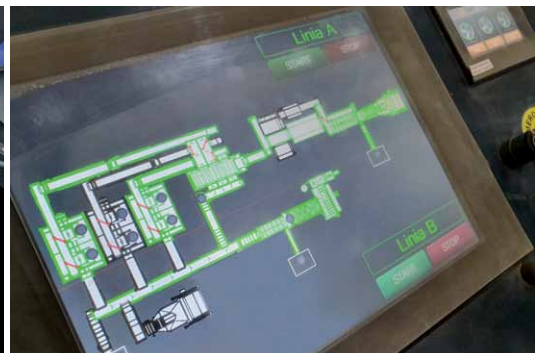

Central control box with a touch screen



WR Weighers are compact devices engineered for weighing and portioning potatoes and other vegetables in the scope of 2,5 kg – 50 kg.

The machines are equipped with, depending on the model, one or two (wide one and narrow one) transport belts, which dose the vegetables into the weighing container. The speed of each belt is freely adjustable, what enables to create any settings that a customer wishes to have. In the working mode with a packing machine, the weighing container opens automatically. In the manual packing mode, weighing containers opens either directly after the portion is ready or after the foot switch is pressed. Legible, user-friendly Mitsubishi display enables a fully intuitive operation of the machine.

As standard the construction of the machine is made of powder-painted steel.

OPTIONAL EQUIPMENT:

- weighing meter with legal approval
- acid-resistant stainless steel construction
- weighing container up to 50 kg of vegetables
- belt adjusted for carrot/parsley
- conveyor belt for packing machine
- product sensor in the receiving hopper
- intake hopper's divider
- additional chutes for different bags

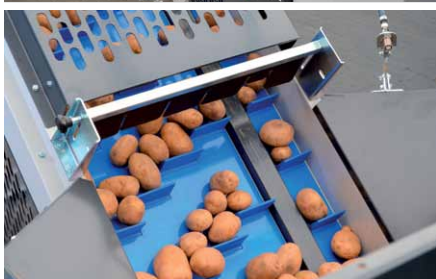

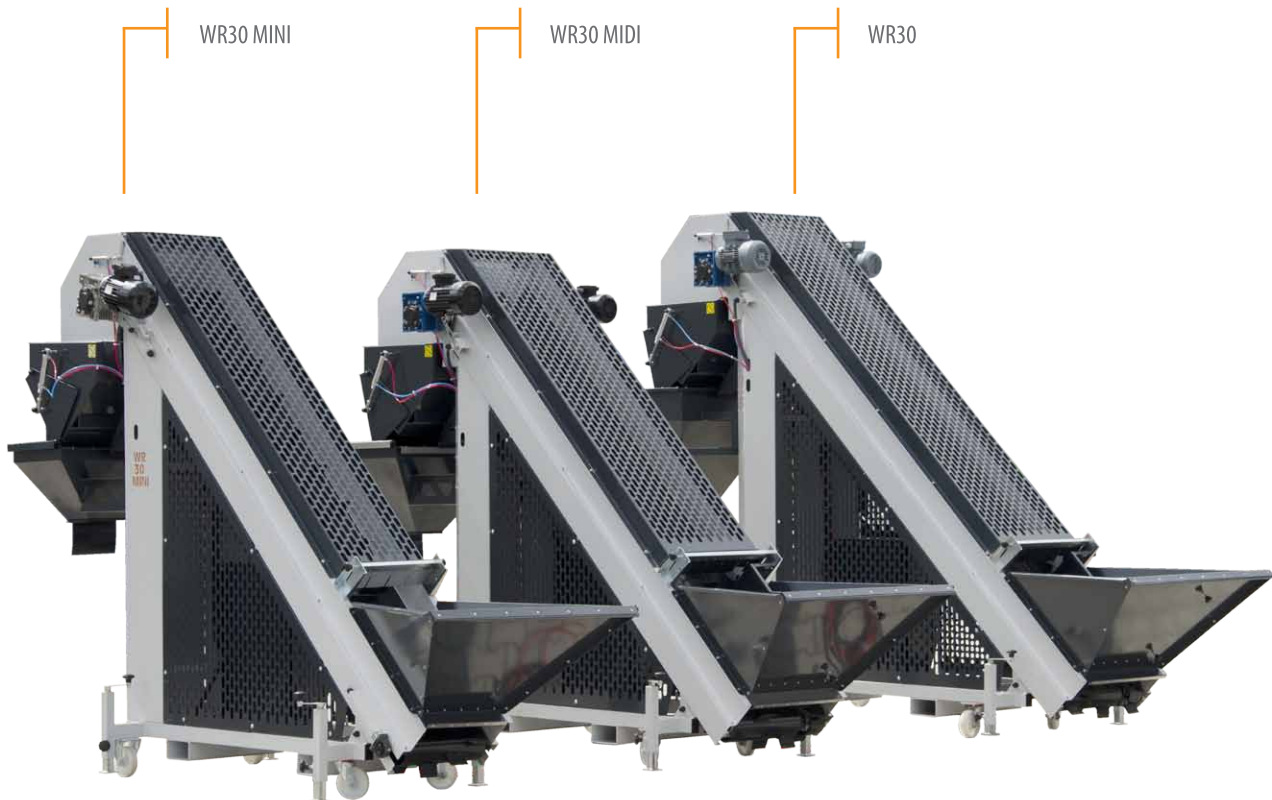

TECHNICAL DATA:

| | WR30 MINI | WR30 MIDI | WR30 | WR50 | WR50 MAXI |
|---------------------------|------------------|----------------------------------|----------------------------------|------------------|------------------|
| Weighing container | 30 kg | 30 kg /50 kg | 30 kg /50 kg | 50 kg | 50 kg |
| Weighing scope | 2,5 kg- 30 kg | 2,5 kg- 30 kg (optionally 50 kg) | 2,5 kg- 30 kg (optionally 50 kg) | 5 kg- 50 kg | 5 kg- 50 kg |
| Max. capacity | 4 t/h* | 5,5 t/h* | 5,5 t/h* | 8 t/h* | 8 t/h* |
| Main belt width | 380 mm | 380 mm | 380 mm | 500 mm | 500 mm |
| Narrow belt width | - | 85 mm | 85 mm | 100 mm | 100 mm |
| Work with packing machine | - | - | up to 25 kg bags | up to 50 kg bags | up to 50 kg bags |
| Touch screen | 4,3" | 4,3" | 7" | 7" | 7" |
| Electrical supply | 230 V | 400 V | 400 V | 400 V | 400 V |
| Pneumatocal supply | 5-6 bar 35 l/min | 5-6 bar 50 l/min | 5-6 bar 50 l/min | 5-6 bar 50 l/min | 5-6 bar 50 l/min |
| Power consumption | 1,8 kW | 2 kW | 2 kW | 2 kW | 2 kW |

* Capacity depends on the size of the batches.



WK04 Weigher is a compact solution for vegetable growers, who prepare mainly small packages between 2,5 kg and 15 kg and who wants to reach high precision.

WK04 Weigher is equipped with four weighing buckets, 11 l each. Despite the small dimension of the weigher, due to the functionality of the combination weighers, the precision of the weigher is close to the precision of multihead weighers. The weigher is designed to work with KMK packaging machines: R1/R2 Raschel packing machine and F2 PE-film packing machine.

In a standard model of the machine all the elements which have contact with the weighed products are made of acid-resistant stainless steel. Remaining elements of the weigher are powder-coated.

The standard equipment of the weigher includes: unloading belt, receiving platform sensor and service platform with a ladder. Legible, user-friendly Mitsubishi display enables a fully intuitive operation of the machine.

| TECHNICAL DATA: | |
|----------------------------------|---|
| | WK04 |
| Number of weighing buckets | 4 |
| Capacity of each weighing bucket | 11 l |
| Weighing scope | 1 kg-25 kg (1- 2,5 kg in 1 drop, 2,5-15 kg in 2 drops, <15 kg in 3 drops) |
| Max. capacity | 5,5 t/h |
| Control system | PLC Mitsubishi |
| Touch screen | 7" |
| Electrical supply | 400 V |
| Pneumatical supply | 5-6 bar 50 l/min |
| Power consumption | 2 kW |

OPTIONAL EQUIPMENT:

- loading belt
- all acid-resistant stainless steel construction
- adjustment to carrot, root parsley
- adjustment to manual packing
- buffer container

* Capacity depends on the size of the batches.

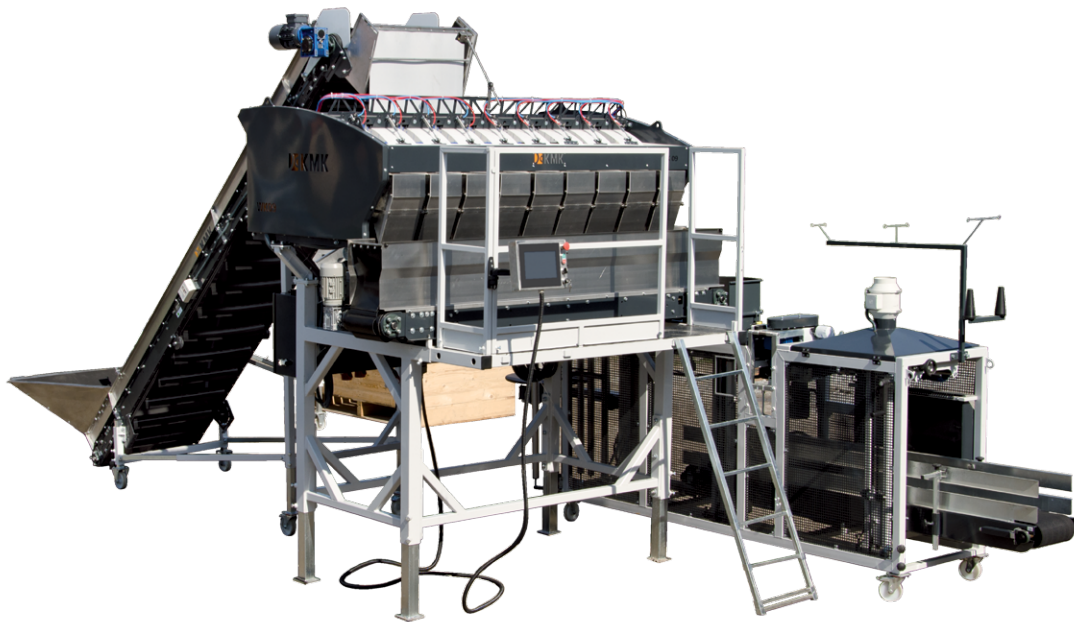

WK Multihead weighers are engineered for professional weighing of potatoes, onions and root vegetables (including carrots and root parsley).

The basic idea of the multihead weighers lies in a number of separate weighing devices (depending on the model 7, 9 or 12), which weigh out smaller batches. The machine automatically chooses the best fitting combination and drops one best-fitting batch. In a standard model of the machine all the elements which have contact with the weighed products are made of acid-resistant stainless steel. Remaining elements of the weigher are powder-coated. The standard equipment of the weigher includes: unloading belt, receiving platform sensor and service platform with a ladder. Legible, user-friendly Mitsubishi display enables a fully intuitive operation of the machine. Optionally the weighers can be fitted with buffer containers, which increase the capacity.

| TECHNICAL DATA: | | | | |
|----------------------------------|------------------|-------------------|-------------------|-------------------|
| | WK07 | WK09 | WK12 | WK12-M |
| Number of weighing buckets | 7 | 9 | 12 | 12 |
| Capacity of each weighing bucket | 11 l | 11 l | 11 l | 6 l |
| Weighing scope | 1 kg- 25 kg | 1 kg- 25 kg | 1 kg- 25 kg | 1 kg- 25 kg |
| Capacity [pack./min] | 8,5 t/h* | 13,5 t/h* | 16,5 t/h* | 16,5 t/h* |
| Control system | PLC Mitsubishi | PLC Mitsubishi | PLC Mitsubishi | PLC Mitsubishi |
| Touch screen | 7" | 7" | 7" | 7" |
| Electrical supply | 400 V | 400 V | 400 V | 400 V |
| Pneumatical supply | 5-6 bar 90 l/min | 5-6 bar 115 l/min | 5-6 bar 150 l/min | 5-6 bar 150 l/min |
| Power consumption | 2,5 kW | 3 kW | 3,5 kW | 3,5 kW |

OPTIONAL EQUIPMENT:

- loading belt
- all acid-resistant stainless steel construction
- adjustment to carrot, root parsley
- adjustment to manual packing
- ability to connect three packaging machines
- buffer container

* Capacity depends on the size of the batches.

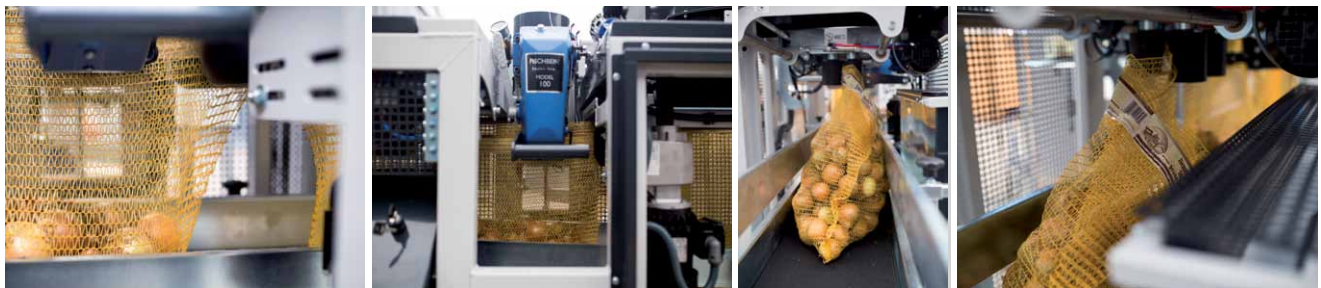

R1/ R2 Packing Machines are engineered for packing potatoes, onions, carrots, root parsley or beets into mesh bags from 2,5 kg to 25 kg.

The principle of operation consists in cutting the bags from the rollstock, filling them with a portion of vegetables and sewing them. R2 Packing machine is equipped with double-thread Fischbein F100 sewing head, while R1 packing machine is equipped with a single-thread Fischbein/Newlong sewing head. An ultrasonic sensor mounted on the intake hopper controls its throughput, preventing disruption caused by an accidental jamming of the products in the hopper.

Optionally the machine can be equipped with: an intake hopper vibration engine, which helps the product to fall down and a conveyor belt vibration engine, which makes the filled bag tremble so that the entangled vegetables fit evenly in the bag, what is especially important in the packaging of root vegetables.

R1/R2 Packing machines are adjusted to work with WK and WR30 weighers. As standard the construction of the machine is made of powder-painted steel.

Legible, user-friendly Mitsubishi display enables a fully intuitive operation of the machine.

TECHNICAL DATA:

| | R1 | R2 |
|--------------------|----------------------------|------------------|
| Sewing head | New Long NP-7A/Fischbein F | Fischbein F100 |
| Packing scope | 2,5 kg - 25 kg | 2,5 kg - 25 kg |
| Control system | PLC Mitsubishi | PLC Mitsubishi |
| Touch screen | 4,3" | 4,3" |
| Electrical supply | 400 V | 400 V |
| Pneumatical supply | 5-6 bar 30 l/min | 5-6 bar 30 l/min |
| Power consumption | 3,2 kW | 3,2 kW |

OPTIONAL EQUIPMENT:

- acid-resistant stainless steel construction
- intake hopper vibration engine
- belt vibration engine
- intake hopper reducer
- thermal transfer printer
- ventilators for exhaust fumes

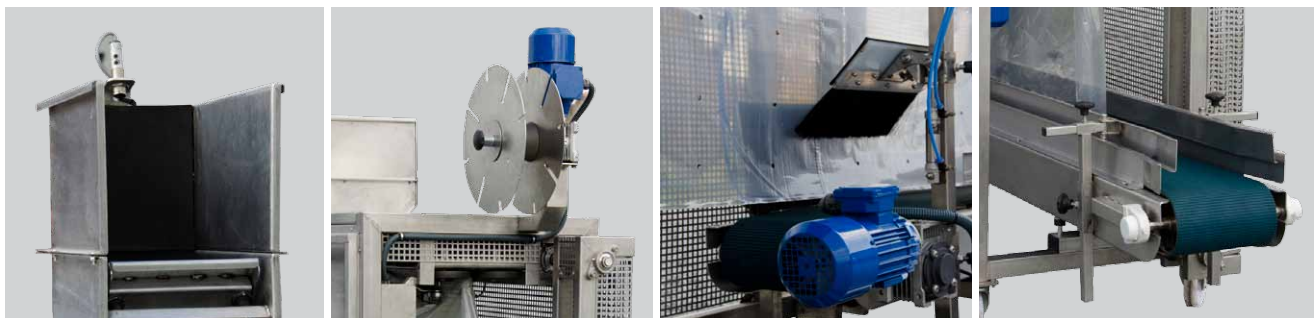
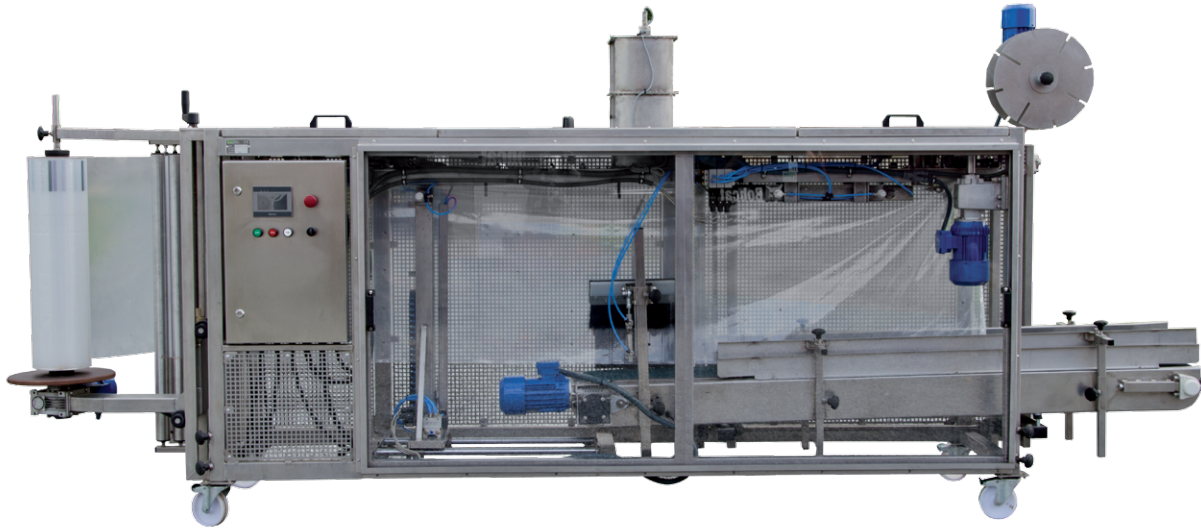

F2 Packing Machine is a professional device for filling and closing PE-film bags.

F2 Packing Machines is used mainly for packing washed carrots and root parsley. A standard model of the machine is made from acid-resistant stainless steel, which makes it resistant to harmful influence of wet vegetables on its construction.

The principle of operation consists in cutting the bags from the rollstock, filling them with a portion of vegetables and closing them. An ultrasonic sensor mounted on the intake hopper controls its throughput, preventing disruption caused by an accidental jamming of the products in the hopper. As standard the machine is equipped with: an intake hopper vibration engine, which helps the product to fall down and a conveyor belt vibration engine, which makes the filled bag tremble so that the entangled vegetables fit evenly in the bag, what is especially important in the packaging of root vegetables.

F2 Packing Machine can work with WR30 and WK weigher.

F2 Packing Machine is available in three variants: with packing scope of 1kg – 2,5 kg, 2,5 kg - 5 kg and 5 kg – 10 kg.

TECHNICAL DATA:

| | F2 |
|--------------------|---------------------------------|
| Packing scope | 1-2,5 kg or 2,5-5 kg or 5-10 kg |
| Control system | PLC Mitsubishi |
| Touch screen | 4,3" |
| Electrical supply | 400 V |
| Pneumatical supply | 5-6 bar 50 l/min |
| Power consumption | 2,5 kW |

OPTIONAL EQUIPMENT:

- thermal transfer printer

FP Pallet shaper



FP pallet shaper is a simple device that allows you to optimize the process of stacking bags on a pallet.

The device consists of three walls that set limits for bags being stacked on a pallet and a lowered front wall, which, depending on the mounting depth, determines the size of the EURO-pallet (1,2 m x 0,8 m) or an industrial pallet (1,2 m x 1,0 m).

The shaper with dimensions slightly smaller than the dimensions of the pallet itself guarantees the tight stacking of bags and regular shape of the load on the pallet, and thus comfortable loading onto the truck.

Removing the loaded pallet from the shaper is trouble-free. Thanks to the fact that two walls of the shaper are hinged, it can be opened to form the letter "L" and moved on the wheels. This solution ensures that during removing a loaded pallet, the walls of the device do not rub against the stacked bags and do not deform the shape of the load.

TECHNICAL DATA:

| | FP |
|----------------------|-----------------------------------|
| Loading height | 1,8 m |
| Suitable for pallets | 1,2 m x 0,8 m or 1,2 m x 1,0 m |

Rotary table TO



TO Rotary table is a device used for buffering packages before they are manually stacked in boxes or on pallets.

The rotary table is positioned directly after a packing machine. The operator who stacks packages on a pallet or in a box takes them from the rotary table, which acts as a buffer, ensuring continuity of work. The frame of the table is made of powder coated steel, while the table top is made of a water-resistant plywood.

Optionally, the entire device can be made of acid-resistant steel. The speed of rotation of the table top is mechanically adjusted by changing the drive position of the drive in relation to the axis of rotation.

TECHNICAL DATA:

| | TO 120 | TO 150 |
|-------------------|------------------|------------------|
| Table top height | 0,6 m (+/-0,2 m) | 0,6 m (+/-0,2 m) |
| Table diameter | 1,2 m | 1,5 m |
| Power consumption | 0,2 kW | 0,2 kW |

OPTIONAL EQUIPMENT:

- sidewalls



BNS crate filler is engineered for an automatic packing of potatoes, onions, carrots or other hard vegetables in plastic crates or cardboard boxes with dimensions of 400 mm x 600 mm.

BNS filler working principle lies in receiving and buffering a weighed portion of vegetables and filling an empty crate with it. The shift of the empty crate to the place when it is filled and the shift of the filled crate to the next stage in the technological line are fully automatic.

BNS filler can be equipped with:

- a conveyor belt for buffering stacks of empty crates,
- a crates feeder, which is designed for separating a crate from a stack of crates.



The machine replaces the less efficient, more labor-intensive and capital-intensive manual method of packaging. The use of BNS crate filler allows to reduce the number of employees handling the process to one person, whose task is to collect the filled crate. As standard the construction of the machine is made of powder-painted steel.

TECHNICAL DATA:

| | BNS 1 | BNS 2 |
|----------------------------|-----------------------------------|-------|
| Number of buffer container | 1 | 2 |
| Crates dimensions | 0,4 m x 0,6 m (different heights) | |
| Control system | PLC Mitsubishi | |
| Touch screen | 4,3" | |
| Electrical supply | 400 V | |
| Pneumatical supply | 5-6 bar 4 l/min | |
| Power consumption | 0,5 kW | |

Selection tables are engineered for manual section of potatoes, onions and other round potatoes. There are three models of selection tables available:

ROLLER SELECTION TABLES TYPES

| | T | TS | TR |
|-------------------------|--|--|---|
| |  |  |  |
| Working mode | Standing position | Sitting position | Sitting position |
| Dirt removal system | - | - | Belt collecting dirt under the rollers draining them to a pull-out drawer |
| Roller speed adjustment | Common adjustment for the travel speed and the rotation speed of the roller | Common adjustment for the travel speed and the rotation speed of the roller | Independent adjustment for the travel speed and the rotation speed of the roller |

Depending on the customer's choice, the rolls in the selection table can be made of white PCV or acid-resistant stainless steel. The rolls moving along the table's frame make vegetables rotate, what enables their selection. The rolls' speed is freely adjustable by means of an inverter. The standard equipment includes lighting. There are many possible configurations of partitions and chutes for the disposal of waste product available.

As standard the construction of the machine is made of powder-painted steel.

OPTIONAL EQUIPMENT:

- all acid-resistant stainless steel construction
- acid-resistant stainless rolls
- channel and chutes for waste
- conveyor for waste
- bag holder
- potato MAFEX sprayer

| AVAILABLE MODELS: | | Lenght | | |
|-------------------|-------|--------------|--------------|--------------|
| | | 2 m | 2,5 m | 3 m |
| Width | 0,8 m | T/TS/TR 2008 | T/TS/TR 2508 | T/TS/TR 3008 |
| | 1,0 m | T/TS/TR 2010 | T/TS/TR 2510 | T/TS/TR 3010 |
| | 1,2 m | T/TS/TR 2012 | T/TS/TR 2512 | T/TS/TR 3012 |

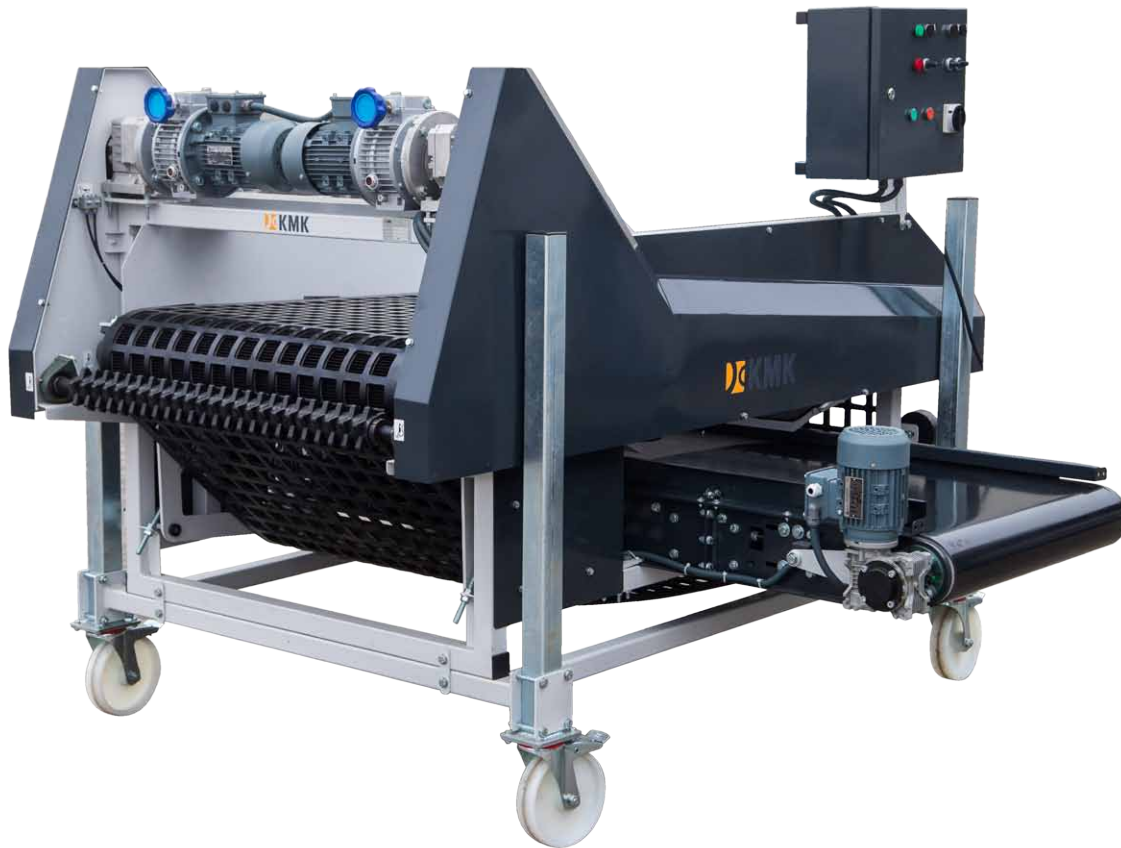

SO Belt grader is a high-speed and highly precise device engineered for grading round vegetables.

A grader can be equipped either with a rubber or a metal grading belt. A rubber belts with square holes are recommended to grade potatoes. Rubber belts are extremely product-friendly and ensure that potatoes are not going to be damaged. Metal belts with hexagonal holes are usually used for onions. They guarantee highest capacity and precision.

A set of motor-driven shakers mounted under the grading belt toss the vegetables, which makes the grading more effective. The speeds of the grading belt speed and the shakers are adjustable.

A single grading module with one grading belt and an unloading conveyor belt for under-size allows us to get two different sizes of vegetables. Modular construction lets us set any number of modules and get required number of sizes.

As standard the construction of the machine is made of powder-painted steel.

DANE TECHNICZNE:

| | SO 90 | SO 120 |
|-------------------|---------|---------|
| Working width | 920 mm | 1220 mm |
| Capacity | 8 t/h | 12 t/h |
| Electrical supply | 400 V | 400 V |
| Power consumption | 1,90 kW | 1,90 kW |

OPTIONAL EQUIPMENT:

- unloading conveyor belt speed adjustment
- front unloading belt (instead of a chute)
- unloading conveyor belt single fall-damper
- unloading conveyor belt modular fall-damper

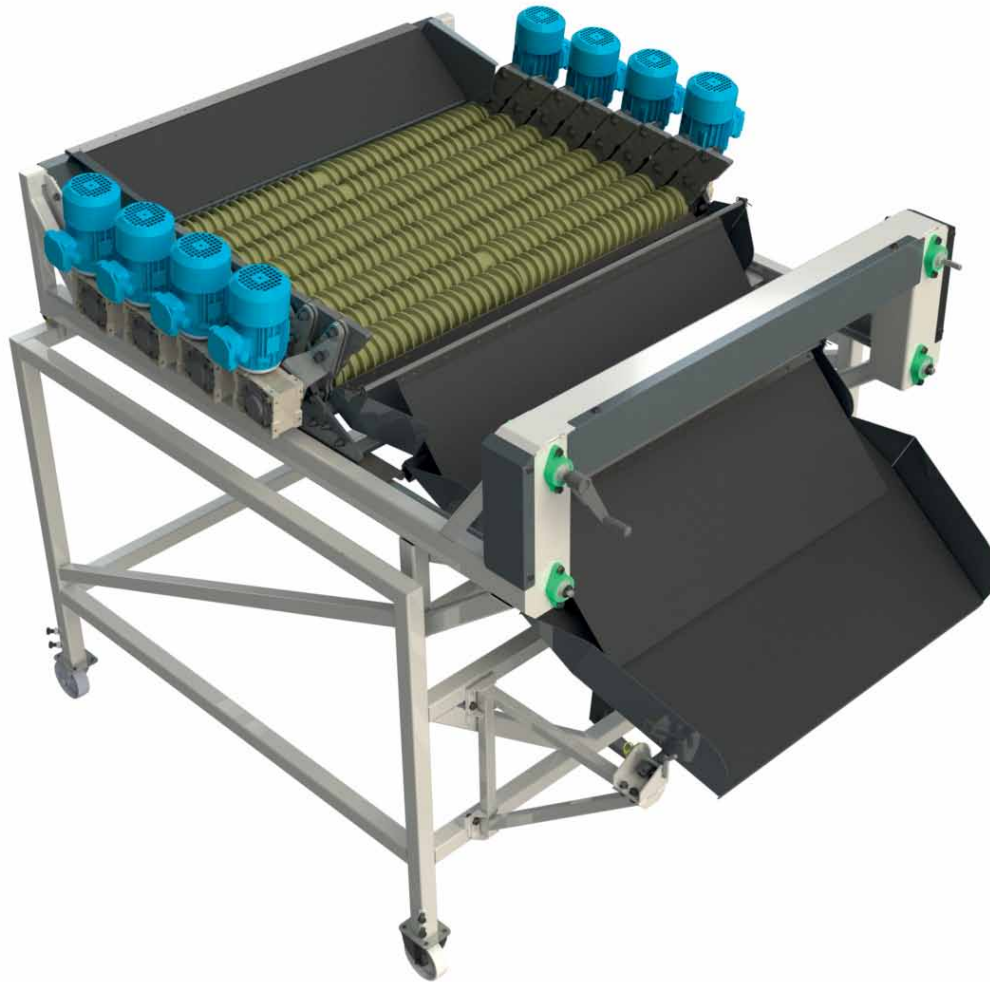

SRZ Separator is a device engineered for pre-cleaning of vegetables from clods of soil, haulm and other small impurities as well as for the sorting out the undersized products.

The separator is equipped with spiral rollers made of polyurethane, 1200 mm wide. The adjustable spacing between the rollers in the range from 5 mm to 55 mm allows the device to be widely used - both to clean vegetables from minor field contamination and to sort out undersized non-commercial product. The rollers spacing is freely adjustable with a convenient crank. The rotational speed of the rollers is adjustable by the means of an inverter.

The working angle is adjustable as well, thanks to which it can be easily integrated into a technological line. The angle adjustment allows also to affect the intensity of the device's work.

As standard the construction of the machine is made of powder-painted steel.

TECHNICAL DATA:

| | SRZ 08-120 |
|-------------------|--------------|
| Number of rollers | 8 pcs |
| Working width | 1200 mm |
| Rollers spacing | 5 mm – 55 mm |
| Electrical supply | 400 V |
| Power consumption | 3,0 kW |



JC Hedgehog is a professional device used to separate clods of soil, haulm and other small impurities from potatoes.

A wide belt with rubber pintles is the working element of the device. Dirty potatoes fall on the belt and they are moved on the pintles towards the chute. The customer can decide on the product flow direction using one of the chutes mounted both on the left and right side of the machine. The field contamination gets between the pintles of the belt and it is moved straight to the waste chute. Above the belt there is a set of two active rollers made of acid-resistant steel. It has double function. Firstly, it directs the potatoes onto chosen chute. Secondly, it ensures that the haulm comes out from between the belt pintles and it moves it straight towards the waste chute.

The speed of the belt and the rotational speed of the rollers are smoothly adjustable by the means of an inverter.

The well-thought-out design of the machine enables 3-dimension adjustment of its working angle and 2-dimension adjustment of the rollers angle.

As standard the construction of the machine is made of powder-painted steel.

TECHNICAL DATA:

| | JC 20 | JC 25 | JC 30 |
|-------------------|--------|--------|--------|
| Working width | 1,0 m | 1,0 m | 1,0 m |
| Working length | 2,0 m | 2,5 m | 3,0 m |
| Electrical supply | 400 V | 400 V | 400 V |
| Power consumption | 3,0 kW | 3,0 kW | 3,0 kW |



OS Onion topper is a stationary device engineered for topping onion.

A vibrating sieve and a cutting unit located directly below it are the machine's working elements.

Onions moving along the sieve's bars are gently tossed, thanks to what knives rotating at a speed up to 1500 rpm clean the onions from dried chives and loose skins.

The spacing between the sieve's bars is 28 mm, what allows separation of non-tradable goods. Optionally, the sieve's vibration's intensity can be freely adjusted by means of an inverter.

The machine is sealed in the area of the waste output, which makes it easier to keep the workplace clean. Mounting the sieves onto vibro-isolators limits vibrations transferred to the frame and ensures quiet operation.

The device has been designed in accordance with the highest safety standards. Thanks to the electromagnetic locks, the opening of the covers is only possible after the knives have come to a complete stop, and their activation only after the covers have been closed. As standard the construction of the machine is made of powder-painted steel.

TECHNICAL DATA:

| | OS 1 | OS 2 | OS 3 |
|-------------------|---------|---------|---------|
| Number of knives | 1 | 2 | 3 |
| Max. capacity | 4 t/h | 8 t/h | 12 t/h |
| Sieve width | 900 mm | 900 mm | 900 mm |
| Electrical supply | 400 V | 400 V | 400 V |
| Power consumption | 2,60 kW | 4,10 kW | 5,80 kW |

OPTIONAL EQUIPMENT:

- waste conveyor
- sieve made of acid-resistant stainless steel
- knives' rotation speed adjustment (inverter)
- vibration intensity adjustment (inverter)



Brush holdfast



Separating springs



Brushing machine with by-pass & waste bucket

S Series Brushing Machines are engineered for dry cleaning of potatoes, onions and other root vegetables.

Each machine is equipped with nylon, wavy brushes. PVC cover limits dust and enhance cleaning effect. Adjustable height of the supporting legs allows you to set the machine at any angle. As standard the construction of the machine is made of powder-painted steel.

OPTIONAL EQUIPMENT:

- adjustable brushes speed (inverter)
- separating spring instead of a brush
- adjustable brush holdfast
- dust absorption system
- waste bucket
- by-pass conveyor

| AVAILABLE MODELS | | Numbers of brushes | | | |
|------------------|--------|--------------------|--------|--------|--------|
| | | 10 pcs | 12 pcs | 14 pcs | 16 pcs |
| Working width | 0,55 m | S1055 | S1255 | S1455 | S1655 |
| | 0,80 m | S1080 | S1280 | S1480 | S1680 |
| | 1,10 m | S10110 | S12110 | S14110 | S16110 |

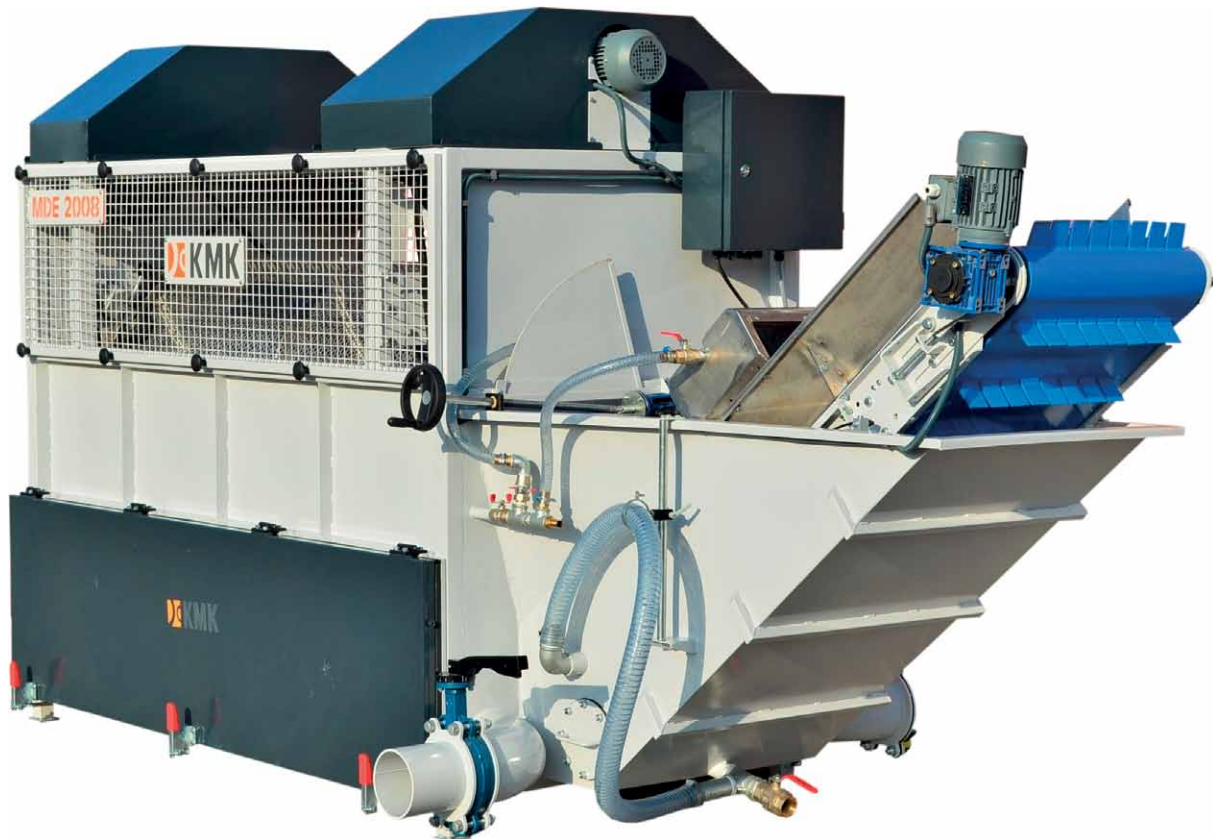

The MDE 2008 washer is a compact drum washer designed for lines with relatively low capacities up to max. 3 t/h.

The washer is equipped with a perforated washing drum with a diameter of 800 mm made of acid-resistant steel. In standard equipped MDE washer there is an output conveyor with a PVC belt and sprinklers installed above it. The after-work cleaning of the washer consist in draining the water and manually selecting the mud. The large diameter of the drain valve of 150 mm guarantees trouble-free water discharge, and the cleaning doors placed symmetrically on both sides of the washer provide easy access to the mud container. As standard the construction of the machine is made of powder-painted steel.

TECHNICAL DATA:

| | MDE 2008 |
|-------------------|----------|
| Drum diameter | 800 mm |
| Drum length | 2000 mm |
| Electrical supply | 400 V |
| Power consumption | 1,5 kW |

OPTIONAL EQUIPMENT:

- all acid-resistant stainless steel construction
- drum rotation's speed adjustment (inverter)
- unloading belt speed adjustment (inverter)
- sprinklers in the drum
- unloading belt with a bar belt (with a swan-neck)



MD washers series include a range of drum washers that, depending on the equipment, can work in any type of a technological line.

MD washers are equipped with a perforated washing drum with a diameter of 1200 mm made of acid-resistant steel. In standard equipped MD washers there is an output conveyor with a PVC belt and sprinklers installed above it. MD series washers are equipped with a bath consisting of two sedimentation hoppers. In the standard version of the equipment, the bath is emptied via mechanically opening valves. In the version with fully-automated control system, the water discharge is automatic, which is guaranteed by pneumatic valves, a water-level sensor and a steering system with a touch screen, which allows to set the frequency and duration of water discharge. As standard the construction of the machine is made of powder-painted steel.

TECHNICAL DATA:

| | MD 2512 | MD 3012 |
|-------------------|---------|---------|
| Drum diameter | 1200 mm | 1200 mm |
| Drum length | 2500 mm | 3000 mm |
| Electrical supply | 400 V | 400 V |
| Power consumption | 2,5 kW | 2,5 kW |

OPTIONAL EQUIPMENT:

- all acid-resistant stainless steel construction
- drum rotation's speed adjustment (inverter)
- unloading belt speed adjustment (inverter)
- sprinklers in the drum
- active brush shaft
- active brush shaft with speed adjustment (inverter)
- fully-automated control system (water level sensor, automatic dump valves, Mitsubishi PLC controller and touch screen)
- unloading belt with a bar belt (with a swan-neck)



DR roller dryers are used to dry wet vegetables that previously were either washed or polished.

The shafts wrapped with moisture-absorbing synthetic felt are the working elements of the machine. The drying shafts are driven by two independent electric motors.

Directly under the drying shafts there is a set of rollers squeezing the moisture out of the felt. The rollers are mounted on an independent spring-loaded system that allows the squeezing degree to be adjusted.

The water squeezed out of the drying shafts flows into a drip tray ended with a drain pipe.

As standard the construction of the machine is made of powder-painted steel.

OPTIONAL EQUIPMENT:

- all acid-resistant stainless steel construction
- contact elements made of acid-resistant stainless steel
- shafts rotation speed adjustment (inverter)

TECHNICAL DATA:

| | DR 10100 | DR 10120 | DR 10150 |
|-------------------|----------|----------|----------|
| Number of shafts | 10 | 10 | 10 |
| Working width | 1000 mm | 1200 mm | 1500 mm |
| Electrical supply | 400 V | 400 V | 400 V |
| Power consumption | 1,5 kW | 1,5 kW | 1,5 kW |



The drum polisher VS is an efficient device engineered for polishing root vegetables.

The machine is designed to work in technological lines where it receives the rinsed product from the washer. The cleaning of vegetables takes place inside a drum made of brush shafts which, turning in the opposite direction to the drum, ensure an optimal cleaning effect. Each shaft is made of segmented brushes of two-different bristles thicknesses. Depending on the machine model, the length of the brush shaft is 2 m or 3 m. Hydraulic adjustment of the machine's working angle and independent adjustment of the brush shafts rotation speed and the drum rotation speed enable the machine to be set suitably for each type of vegetables, regardless of their degree of soiling. Inside the drum there are spray nozzles for two independent water circuits: for clean mains water and for dirty water, e.g. water pumped in a closed circuit from the machine's bath. The opening of the drum outlet shutter is adjusted by a crank.

As standard the construction of the machine is made of powder-painted steel.

VS Polishers has been designed for long-term and intensive operation. As standard, it is equipped with a sealed and maintenance-free brush shaft bearing system, and the well-thought-out design will make it easier to remove the brush shaft for service purposes in the future.

OPTIONAL EQUIPMENT:

- all acid-resistant stainless steel construction
- recycling

TECHNICAL DATA:

| | VS 1420 | VS 1430 |
|------------------------|---------|---------|
| Number of brush shafts | 14 | 14 |
| Working length | 2000 mm | 3000 mm |
| Electrical supply | 400 V | 400 V |
| Power consumption | 14 kW | 18 kW |

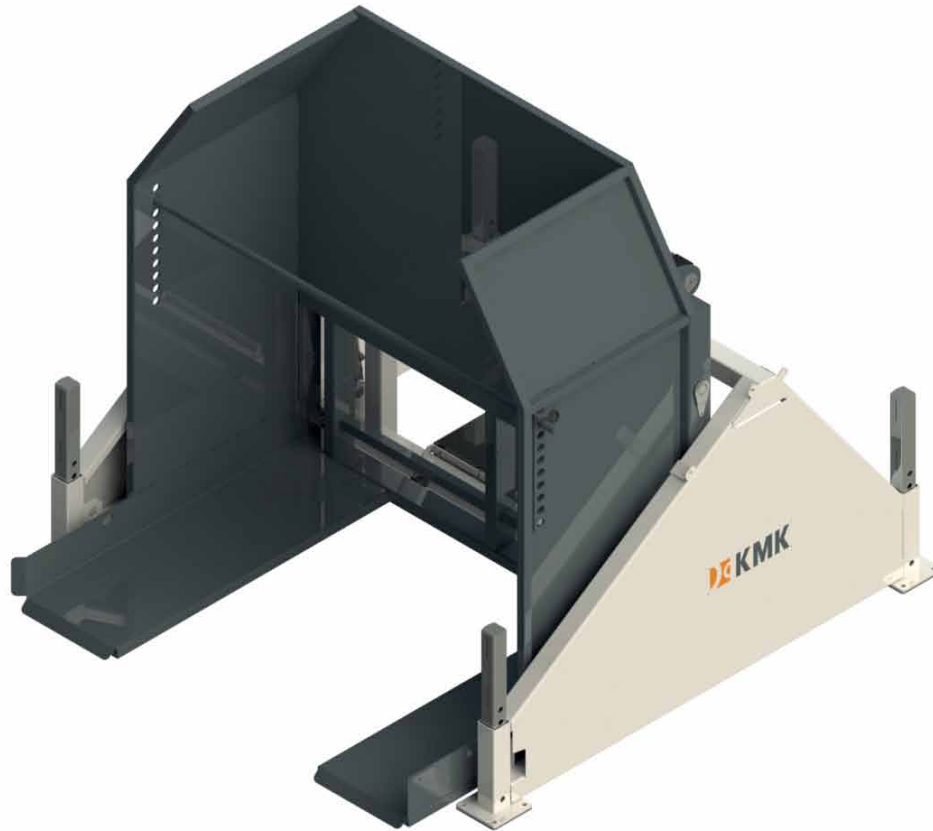

The hydraulic box tipper WSE is an economical variant of the tipper designed for tipping boxes into receiving hoppers and dosing bunkers with the possibility of loading boxes using a manual pallet truck.

WSE Box tippers are equipped with double-acting hydraulic cylinders, a cable-mounted control panel and a powder-coated steel construction. As standard, the tipping process continues until a maximum tipping angle of 140 degrees is reached. Depending on the customer's decision, WSE box tipper can be equipped with a tipping control system with an ultrasonic product sensor.

WSE box tippers are available in three different sizes suitable for three most popular box widths: 1400 mm, 1600 mm and 1800 mm.

OPTIONAL EQUIPMENT:

- tipping control system with product sensor

TECHNICAL DATA:

| | WSE | | |
|--------------------|---------|----------|----------|
| | WS 1412 | WS2 1612 | WS2 1812 |
| Max. box width | 1,4 m | 1,6 m | 1,8 m |
| Max. box height | | 1,3 m | |
| Max. tipping angle | | 140 ° | |
| Electrical supply | | 400 V | |
| Power consumption | | 2,0 kW | |



The hydraulically driven box tipper is a device designed for emptying boxes with vegetables.

Thanks to the special tipping mechanism and equipping the machine with two double-acting cylinders, the maximum tipping angle of the tipper's platform is 180°.

The standard equipment of each box tipper includes an ultrasonic sensor, which by measuring the level of the product in the hopper of a next machine in a line allows to control the tipping of the box, thus ensuring its smooth operation.

Thanks to the radio remote control, the operator can operate the machine without leaving the forklift.

WS Box tipper is available in two equipment variants:

- basic - the tipper is adjusted for feeding to a dispenser (bunker, receiving hopper)
- with a box cover - the tipper can feed directly onto a flat conveyor integrated into the tipper. Such a tipper, thanks to additional equipment (hydraulically controlled box cover and a control panel allowing to parameterize tipper's operation), the tipper can act as a dispenser.

Regardless of equipment variant, WS tipper is available in different sizes: suitable for boxes with width from 1400 mm up to 2400 mm. As standard, the machine is made of powder coated steel.

| TECHNICAL DATA: | | | |
|--------------------|---------|---------|---------|
| | WS | | |
| | WS 1612 | WS 1812 | WS 2012 |
| Max. box width | 1,6 m | 1,8 m | 2,0 m |
| Max. box height | 1,3 m | | |
| Max. tipping angle | 180° | | |
| Electrical supply | 400 V | | |
| Power consumption | 3 kW | | |

OPTIONAL EQUIPMENT (only for a tipper with the box cover):

- crosswise unloading conveyor
- longitudinal unloading conveyor
- automatic dosing control

ZB Dosing bunker is a device designed for unloading boxes and big-bags with vegetables.

TYPES OF THE ZB BUNKERS

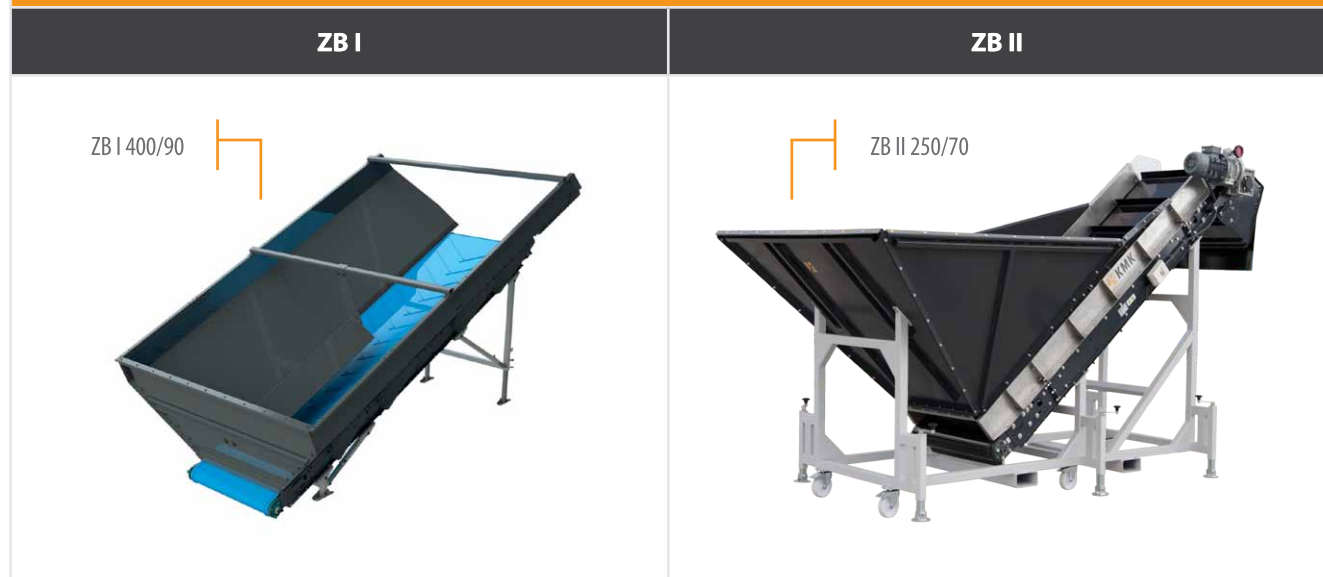

ZB Dosing bunkers are equipped with PVC belt and capacious intake hopper. Over the belt there is a roof-shaped cover, which prevent overloading of the belt. Thanks to stepless speed adjustment by the means of an inverter, the vegetables are evenly fed on the following parts of a technological line. As standard, the inner walls of the intake hopper and the roof-shaped cover mounted above the belt are lined with shock-absorbing material.

ZB dosing bunkers are available in two variants: ZB I and ZB II, which, due to their different mechanical construction, are suitable for different applications in the technological lines.

Optionally the machine can be equipped with a soil separator, which allows to sort out clods and minor field impurities. As standard the construction of the machine is made of powder-painted steel.

OPTIONAL EQUIPMENT:

- all acid-resistant stainless steel construction
- extra-durability shock-absorbing material
- product sensor (for belt work in START-STOP mode)
- extended belt speed adjustment range
- clod separator with an inverter

TECHNICAL DATA:

| | ZB I | | ZB II | | | |
|------------------------------------|--------------------|--------------------|--------------------|--------------------|--------------------|--------------------|
| | ZB I 250/70 | ZBI 400/90 | ZB II 250/70 | ZB II 300/70 | ZB II 350/70 | ZB II 400/70 |
| Belt width | 0,7 m | 0,9 m | 0,7 m | 0,7 m | 0,7 m | 0,7 m |
| Belt length | 2,5 m | 4,0 m | 2,5 m | 3,0 m | 3,5 m | 4,0 m |
| Theoretical capacity | 1,5 m ³ | 3,0 m ³ | 1,2 m ³ | 1,2 m ³ | 1,2 m ³ | 1,2 m ³ |
| Max. outlet height | 1,2 m | 1,5 m | 1,9 m | 2,2 m | 2,5 m | 2,8 m |
| Soil separator possibility | - | - | ✓ | ✓ | ✓ | ✓ |
| Electrical supply | 230 V/ 400 V | 230 V/ 400 V | 230 V/ 400 V | 230 V/ 400 V | 230 V/ 400 V | 230 V/ 400 V |
| Power consumption | 0,60 kW | 0,60 kW | 0,60 kW | 0,60 kW | 0,60 kW | 0,60 kW |
| Power consumption (with separator) | - | - | 1,2 kW | 1,2 kW | 1,2 kW | 1,2 kW |



Even Flow buffering conveyor is a device designed for buffering and precise dosing of the product in critical points of the technological lines, especially for feeding multihead weighers, which require even product supply.

Even Flow is equipped with a movable conveyor with a PVC belt, which in case of an overflow of product, goes down and makes a buffering space. Thanks to the mechanism used and the sensor control system, the device can react dynamically to sudden product overflow, caused either by the next machine in the line being unable to receive the product or the preceding machines faster feeding. The obtained functionality ensures an even and stable product flow between machines in the line.

Standard belt speed is controlled by an inverter. Optionally, the machine can be equipped with an advanced dosing control system, which consists of an additional product sensor and a programmed PLC controller that constantly controls the belt speed, so as to maintain the most steady dosing level possible.

As standard the construction of the machine is made of powder-painted steel.

OPTIONAL EQUIPMENT:

- all acid-resistant stainless steel construction
- substructure for WK weighers
- product sensor (for belt work in speed control mode)

TECHNICAL DATA:

| | EF 100 | EF 125 | EF 150 |
|---------------------------------|--------------------|--------------------|--------------------|
| Belt working width | 1000 mm | 1250 mm | 1500 mm |
| Capacity | 1,7 m ³ | 2,1 m ³ | 2,5 m ³ |
| Compatible with KMK weighers WK | WK07 WK09 WK12 | WK09 WK12 | WK12 |
| Power consumption | 1,0 kW | 1,0 kW | 1,0 kW |

BM Modular bunker



BM Modular bunker is a device used for buffering the product and its even feeding on the following parts of a technological line. BM bunkers may be located at the beginning of a line or anywhere else where there is a need for product buffering.

BM bunkers have modular construction. They consist of a base and sidewalls of 0,5 m high each. The unloading conveyor belt, which is mounted at the bottom of the bunker is equipped with an inverter for stepless speed adjustment, which enables even feeding on the following parts of a technological line. The height of a roof-shaped cover, which prevents overloading of the belt is adjustable by the means of handles. As standard, the inner walls of the bunker base and the roof-shaped cover mounted above the belt are lined with shock-absorbing material. If the bunker is equipped with a ventilator, the clearance above the unloading conveyor can be sealed with a shutter, which allows an effective ventilation.

As standard the construction of the machine is made of powder-painted steel.

| TECHNICAL DATA: | |
|--------------------|--|
| | BM |
| Available width | 1,5 -3,0 m |
| Available length | 1,5-10,0 m |
| Capacity | 1 m ³ -60 m ³ (0,6 t -36 t of potatoes) |
| Belt working width | 0,4 m (for a bunker 1,5 m wide) lub 0,6 m (for a bunker 2,0-3,0 m wide) |
| Electrical supply | 230 V or 400 V |

OPTIONAL EQUIPMENT:

- all stainless acid-resistant steel construction
- extra-durability shock-absorbing material
- additional 3-side top wall
- extended belt speed adjustment range
- product sensor (for belt work in START-STOP mode)
- ventilator
- fixed fall-damper
- inverter with a sensor that controls the speed of an unloading belt
- product level sensor
- ladder or platform



KP Receiving hopper is a device engineered for receiving vegetables directly from a rear-tipping trailer.

KP Receiving hoppers are equipped with a durable rubber belt with vulcanized paddles, the speed of which is freely adjustable by a frequency inverter. In a basic configuration the machine has pneumatic wheels and a detachable tow-bar, which ensure its mobility. Depending on its technical configuration the receiving hopper has a single or a double soil separator and up to three output conveyor belts. The distance between separating rolls is adjustable.

The main belt and the output conveyors are electrically driven, while the soil separator, depending on the customer, is equipped either with an electric drive or a hydraulic drive with self-cleaning system.

OPTIONAL EQUIPMENT:

- single/double soil separator with polyurethane spiral shafts with one/two/three unloading belts
- output conveyor belts speed adjustment (inverter)
- product sensor (for belt work in speed control mode)
- discharge belt fall-damper
- shock-absorbing fingers

TECHNISCHE GEGEVENS:

| | KP 4014 | KP 4016 |
|----------------------------------|------------------|------------------|
| Capaciteit | 6 m ³ | 7 m ³ |
| Stortbak breedte | 2400 mm | 2600 mm |
| Werkbreedte van de bodem ketting | 1400 mm | 1600 mm |
| Werkbreedte rollenset | 1600 mm | 1800 mm |
| Lengte van de bodem ketting | 4000 mm | 4000 mm |
| Elektrische voeding | 400 V | 400 V |
| Geïnstalleerd vermogen | 7,35 kW | 7,55 kW |

NB Fall-damper filler



NB Filler is a universal device used for filling both BIG-BAGs and boxes with potatoes and other vegetables.

The key feature of the NB fall-damper filler is its versatility. Depending on the operator's choice the device can be used as a BIG-BAG filler or as a box filler.

The device is equipped with a fall-damper, which lifts automatically, while the product level is rising. The fall-dampers are made of two-layer, robust PVC material. The filling process is controlled by a dust-resistant ultrasonic sensors. The filling is completed once the BIG-BAG/box is full or once the set weight was reached.

Installing an empty BIG-BAG was simplified thanks to an electrical control of the arms. After pressing a button, the machine automatically prepares all the working elements to hanging a BIG-BAG. When the machine is properly parameterised it doesn't require any adjustments: the filler automatically adjust the height of the working elements to the BIG-BAG size.

Taking the filled BIG-BAG out is also automatic. Once the bag is filled, suitably shaped handles on which the bag is hanged lower automatically to a position that enables the operator to take the BIG-BAG out without walking out of the forklift.

As standard the construction of the machine is made of powder-painted steel.

TECHNICAL DATA:

| | NB1 | NB2 |
|-----------------------------|----------------|----------------|
| Number of falldumpers /unit | 10 | 10 |
| Number of filling units | 1 | 2 |
| Control system | PLC Mitsubishi | PLC Mitsubishi |
| Touch screen | 4,3" | 4,3" |
| Electrical supply | 400 V | 400 V |
| Power consumption | 1 kW | 2,5 kW |

OPTIONAL EQUIPMENT:

- loading belt
- weighing system
- remote controller



The machine is designed for filling boxes with potatoes and other vegetables.

The device is equipped with a crosswise conveyor and two platforms that lift the boxes up. While filling, the device automatically lowers the platform with a box. That provides a safety dump for the product, which is not exposed to damages. The crosswise conveyor moves over the box, what provides an even and precise filling. Evenly filled boxes can be easily stacked up. After filling one of the box, the device automatically switches the belt to an opposite direction and starts filling the other one, what ensures high capacity.

As standard, the filler fills the box in a simple sequence: lowering the box and moving the crosswise conveyor to its end. Optionally, the filler can be equipped with an additional sensor system that allows filling the box in a three-stage sequence. Three-stage filling ensures more even distribution of field contaminants (e.g. soil clods, haulm) in the box and thus more effective ventilation.

The filling process is controlled by a dust-resistant ultrasonic sensors. Optionally a box filler can be equipped with a weighing system that controls the filling process.

As standard the construction of the machine is made of powder-painted steel.

TECHNICAL DATA:

| | NS2 |
|-------------------|----------------|
| Control system | PLC Mitsubishi |
| Touch screen | 7" |
| Electrical supply | 400 V |
| Power consumption | 3 kW |

OPTIONAL EQUIPMENT:

- loading conveyor
- weighing system
- three-stage filling possibility

P Stationary conveyor belts



Straight conveyor with adjustable chute

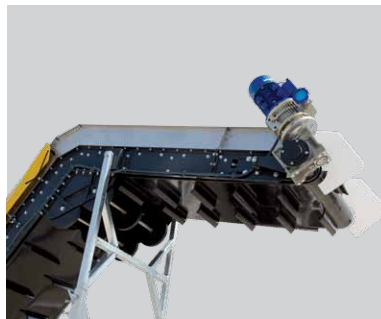

Swan-neck conveyor

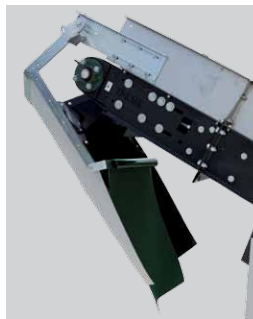

Fall-damper



Belt cover

KMK offers wide range of stationary conveyor belts, both elevators and horizontal conveyors. Each stationary conveyor belt produced by KMK is fully customized.

There are two types of stationary conveyor belts available: horizontal conveyors with smooth PVC belt and elevators, which are equipped with PVC belt with paddles. Elevating conveyors are equipped with infeed hoppers made of acid-resistant steel covered with soft-landing foam. Optionally elevators can be equipped with adjustable outlet chute or a swan-neck.

All the values like: conveyor's length, belt's width, inlet and outlet heights, conveyor's angle as well as details like belt's speed and the arrangements of paddles at the belt are each time to be agreed with the customer.

As standard the construction of the machine is made of powder-painted steel. All the elements which have contact with the products are made of acid-resistant steel.

TECHNICAL DATA:

| | P |
|-------------------|----------------|
| Available widths | 0,2 m - 1,0 m |
| Available lengths | 0,5 m - 14 m |
| Belt typ | PVC belt |
| Electrical supply | 230 V or 400 V |

OPTIONAL EQUIPMENT:

- all acid-resistant stainless steel construction
- swan-neck
- top cover (tarpaulin)
- speed adjustment (inverter)
- fall-damper



KMK offers wide range of light mobile conveyors, which are an extended version of the stationary conveyors.

PLM Conveyors are elevating conveyors equipped with:

- PVC belt with paddles,
- transport wheels
- and a rewinder for manual height adjustment.

PLM conveyors are equipped with infeed hoppers made of acid-resistant steel covered with soft-landing foam. Optionally elevators can be equipped with adjustable outlet chute or a swan-neck.

All the values like: conveyor's length, belt's width, inlet and outlet heights, conveyor's angle as well as details like belt's speed and the arrangements of paddles at the belt are each time to be agreed with the customer.

Optionally the belt's speed can be adjusted by means of an inverter.

As standard the construction of the machine is made of powder-painted steel. All the elements which have contact with the products are made of acid-resistant steel.

OPTIONAL EQUIPMENT:

- swan-neck
- all acid-resistant stainless steel construction
- speed adjustment (inverter)
- top cover (tarpaulin)

| TECHNICAL DATA: | |
|-------------------|-----------------|
| | PLM |
| Available widths | 0,30 m - 0,90 m |
| Available lengths | 2,00 m - 7,00 m |
| Belt type | PVC belt |
| Electrical supply | 230 V or 400 V |



PM Mobile conveyor belt is a general-purpose conveyor. Thanks to a wide height adjustment scope and mobile construction adjusted to easy transporting, the conveyor is a versatile machine.

PM Mobile conveyor belts are equipped with a motor with hydraulic pump, which enables stepless height adjustment, a rubber belt with a herringbone paddles and a capacious intake hopper.

Belt's speed and loading height are easily adjustable by the means of wired remote controller. PM conveyors are based on a mobile frame with pneumatic wheels, enabling moving the conveyor easily. Additionally PM conveyors are equipped with supporting feet that help to turn the wheels and stabilize the conveyor in a chosen position. The standard equipment of the machine includes detachable drawbar for coupling the conveyor with a tractor.

All the elements listed above and very robust construction make the conveyor a versatile machine, which can be used for: piling up prisms, filling trailers, loading product on box fillers or any other machines in technological lines.

As standard the construction of the machine is made of powder-painted steel.

OPTIONAL EQUIPMENT:

- inverter for speed adjustment
- steering wheels with supporting legs
- automatic fall-damper

| AVAILABLE MODELS | | Length | | | |
|-----------------------|--------|----------|----------|----------|-----------|
| | | 7,5 m | 8,5 m | 9,5 m | 10,5 m |
| Width | 0,65 m | P 750/65 | P 850/65 | P 950/65 | P 1050/65 |
| | 0,80 m | P 750/80 | P 850/80 | P 950/80 | P 1050/80 |
| Max. unloading height | | 4,0 m | 4,5 m | 5,0 m | 5,5 m |

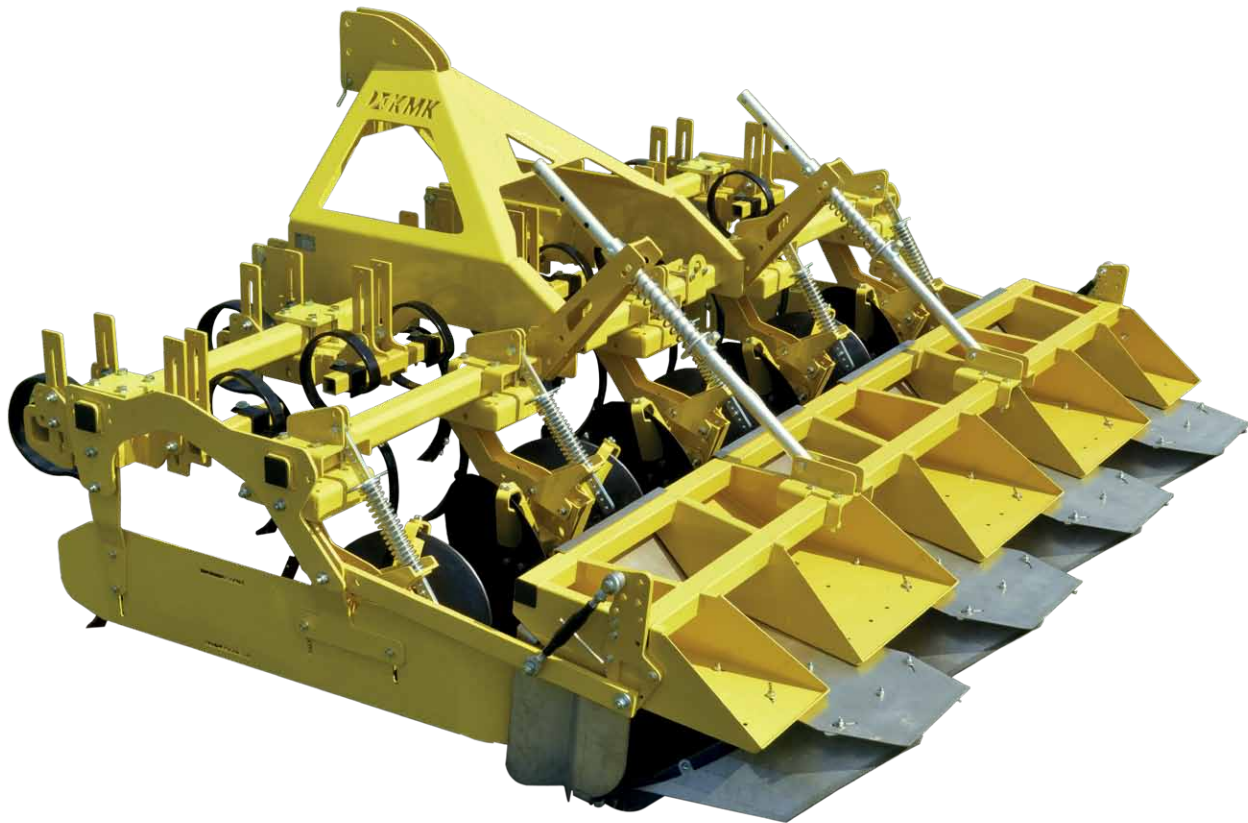

OF Ridging hillers are used for forming ridges in potatoes or root vegetables grown on ridges. The use of the OF forming hillers can significantly increase the yield. Formed ridges make better conditions for growing potatoes by reducing the risk of their exposure to light and increasing the moisture retention in the ridge.

Hillers are available in two variants: double-row and four-row with a fixed row spacing of 75 cm.

Thanks to the use of replaceable parts, the device can be adapted to different types of soil. The ridging hiller is available either with ridging discs or tines.

The use of a solid frame allows to mount a wide range of loosening tines and ridging elements in various configurations. The pressure of the forming section is spring-loaded, which results in a more precise shaping effect. Optionally on the forming sheet there can be mounted an element, which shapes a depression in the ridge, where rainwater stops.

Alternatively, hillers can be used to form ridges before sowing root vegetables and (after dismantling some elements) work in potatoes or root vegetables after their emergence.

TECHNICAL DATA:

| | OF-275 | OF-475 |
|----------------|--------|--------|
| Row width | 0,75 m | 0,75 m |
| Number of rows | 2 | 4 |

OPTIONAL EQUIPMENT:

- ridging tines instead of ridging discs



KMK-PRODUCER OF AGRICULTURAL MACHINERY

Brodowo, ul. Poznańska 20, 63-000 Środa Wlkp.

Phone: 00 48 61 287 11 46, **phone/fax:** 00 48 61 285 01 79

e-mail: biuro@kmk-maszyny.com

web: www.kmk-maszyny.com



European Funds
Smart Growth



Republic of Poland



Polska

European Union
European Regional Development Fund

